

# Heathfield&Co

## Product Specification Sheet

TABLE LAMP | ORLA SATIN BRASS



### PRODUCT INFORMATION

Base Code: TL-ORLA-SBRS-SPEC

Material: Metal & Glass

Finish shown: Speckle

Metalwork: Satin Brass

Flex: UK & EU 1.5 metres of Black PVC flex /  
US Black PVC flex

### TECHNICAL INFORMATION

Weight: 1.9kg / 4.2lbs

Plug: Black 13amp UK plug /

Black Schuko EU plug / Black US polarised plug

Switching: Black inline switch

Lamping: 1x G9 Capsule LED Bulb. 2.2W 2700K 200LM.

Supplied with our recommended Crompton bulb (when selected).

TOTAL HEIGHT: 140 mm / 5<sup>1</sup>/<sub>2</sub>"

BASE WIDTH: 240 mm / 9<sup>1</sup>/<sub>2</sub>"

UKCA / CE / WIRED USING US COMPONENTS

### WARRANTY

10 years\*

### FINISHING NOTE

Our carefully selected glass and metalwork components are all hand finished by skilled artisans and as such no two products are exactly the same - something that adds to the unique charm of this product.

### CLEANING INSTRUCTIONS

The finishes on this luminaire only require regular cleaning with a soft dry duster. Abrasive or chemical cleaners may harm the finish and should not be used.

### FIXING NOTE

It is the buyer's responsibility to ensure that suitable fixings are used.

\*Please refer to our Terms & Conditions for further information.

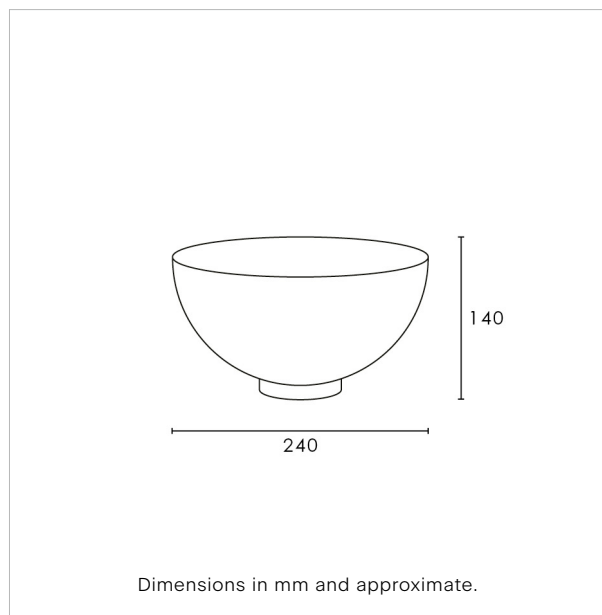

H&  
CO

LIGHT BEYOND DESIGN

www.heathfield.co.uk | + 44 (0) 1732 350450 | sales@heathfield.co.uk  
Unit 1, Priory Road, Tonbridge, Kent, TN9 2AF, United Kingdom. This specification is subject to our standard Terms & Conditions, a copy of which can be found at heathfield.co.uk. © 2026 Heathfield & Co. All rights reserved.

# Heathfield&Co

## Product Specification Sheet

TABLE LAMP | ORLA BLACKENED BRONZE



### PRODUCT INFORMATION

Base Code: TL-ORLA-BRNZ-SPEC

Material: Metal & Glass

Finish shown: Speckle

Metalwork: Blackened Bronze

Flex: UK & EU 1.5 metres of Black PVC flex /  
US Black PVC flex

### TECHNICAL INFORMATION

Weight: 1.9kg / 4.2lbs

Plug: Black 13amp UK plug /

Black Schuko EU plug / Black US polarised plug

Switching: Black inline switch

Lamping: 1x G9 Capsule LED Bulb. 2.2W 2700K 200LM.

Supplied with our recommended Crompton bulb (when selected).

TOTAL HEIGHT: 140 mm / 5<sup>1</sup>/<sub>2</sub>"

BASE WIDTH: 240 mm / 9<sup>1</sup>/<sub>2</sub>"

UKCA / CE / WIRED USING US COMPONENTS

### WARRANTY

10 years\*

### FINISHING NOTE

Our carefully selected glass and metalwork components are all hand finished by skilled artisans and as such no two products are exactly the same - something that adds to the unique charm of this product.

### CLEANING INSTRUCTIONS

The finishes on this luminaire only require regular cleaning with a soft dry duster. Abrasive or chemical cleaners may harm the finish and should not be used.

### FIXING NOTE

It is the buyer's responsibility to ensure that suitable fixings are used.

\*Please refer to our Terms & Conditions for further information.

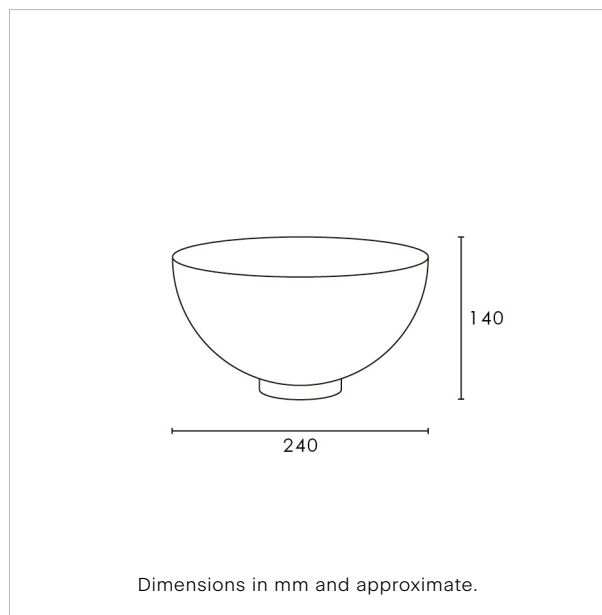

H&  
CO

LIGHT BEYOND DESIGN

www.heathfield.co.uk | +44 (0) 1732 350450 | sales@heathfield.co.uk  
Unit 1, Priory Road, Tonbridge, Kent, TN9 2AF, United Kingdom. This specification is subject to our standard Terms & Conditions, a copy of which can be found at heathfield.co.uk. © 2026 Heathfield & Co. All rights reserved.