

# Heathfield&Co

## Product Specification Sheet

TABLE LAMP | MABEL



### PRODUCT INFORMATION

Base Code: TL-MABE-ABRS-VIOL

Material: Metal & Marble

Finish shown: Calacatta Viola

Metalwork: Antique Brass

Lampshade: 16" Mabel Shade / SH-16-MABE

Flex: UK & EU 1.5 metres of Oatmeal braided flex /

US Oatmeal braided flex

### TECHNICAL INFORMATION

Weight: 16kg / 35.3lbs

Plug: White 13amp UK plug /

White Schuko EU plug / White US polarised plug

Switching: White inline switch

Lamping: 1x E27 Pluto LED Bulb. 3W 2700K 240LM.

Supplied with our recommended Tala bulb (when selected).

BASE HEIGHT: 295 mm / 11<sup>3</sup>/<sub>4</sub>"

TOTAL HEIGHT: 515 mm / 20<sup>1</sup>/<sub>4</sub>"

BASE WIDTH: 245 mm / 9<sup>3</sup>/<sub>4</sub>"

SHADE WIDTH: 405 mm / 16"

UKCA / CE / UL COMPLIANT

### WARRANTY

10 years\*

### FINISHING NOTE

Marble is a natural material with distinctly unique formations, markings and colouration. It is part of its charm that no two lamps are exactly the same. All metalwork is handcrafted and may vary from piece to piece with slight variations in finish and detailing.

### CLEANING INSTRUCTIONS

The finishes on this luminaire only require regular cleaning with a soft dry duster. Abrasive or chemical cleaners may harm the finish and should not be used.

### FIXING NOTE

It is the buyer's responsibility to ensure that suitable fixings are used.

\*Please refer to our Terms & Conditions for further information.

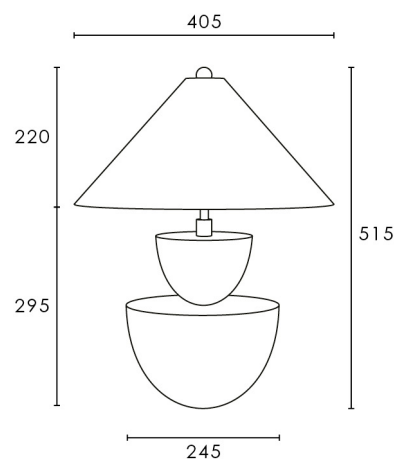

Dimensions in mm and approximate.

H&  
CO

LIGHT BEYOND DESIGN

[www.heathfield.co.uk](http://www.heathfield.co.uk) | +44 (0) 1732 350450 | [sales@heathfield.co.uk](mailto:sales@heathfield.co.uk)

Unit 1, Priory Road, Tonbridge, Kent, TN9 2AF, United Kingdom. This specification is subject to our standard Terms & Conditions, a copy of which can be found at [heathfield.co.uk](http://heathfield.co.uk). © 2026 Heathfield & Co. All rights reserved.