

Heathfield&Co

Product Specification Sheet

FLOOR LAMP | SONNY



PRODUCT INFORMATION

Base Code: FL-SONN-SBRS-GRNF-000

Material: Marble

Finish shown: Forest Green

Metalwork: Satin Brass

Flex: UK & EU 1.5 metres of Oatmeal braided flex /
US Oatmeal braided cable

TECHNICAL INFORMATION

Weight: 11.7kg / 25.8lbs

Plug: White 13amp UK plug /

White Schuko EU plug / White US polarised plug

Switching: White foot switch

Lamping: 1x E27 lampholder / 1x E26 US lampholder
40W max. LED Golf Ball Lamps Recommended.

Lamps not included

BASE HEIGHT: 320mm / 12^{3/4}"

TOTAL HEIGHT: 1570mm / 62"

BASE WIDTH: 145mm / 5^{3/4}"

SHADE WIDTH: 405 mm / 16"

UKCA / CE / UL COMPLIANT

WARRANTY

10 years*

FINISHING NOTE

Marble is a natural material with distinctly unique formations, markings and colouration. It is part of its charm that no two lamps are exactly the same. All metalwork is handcrafted and may vary from piece to piece with slight variations in finish and detailing.

CLEANING INSTRUCTIONS

The finishes on this luminaire only require regular cleaning with a soft dry duster. Abrasive or chemical cleaners may harm the finish and should not be used.

FIXING NOTE

It is the buyer's responsibility to ensure that suitable fixings are used.

*Please refer to our Terms & Conditions for further information.

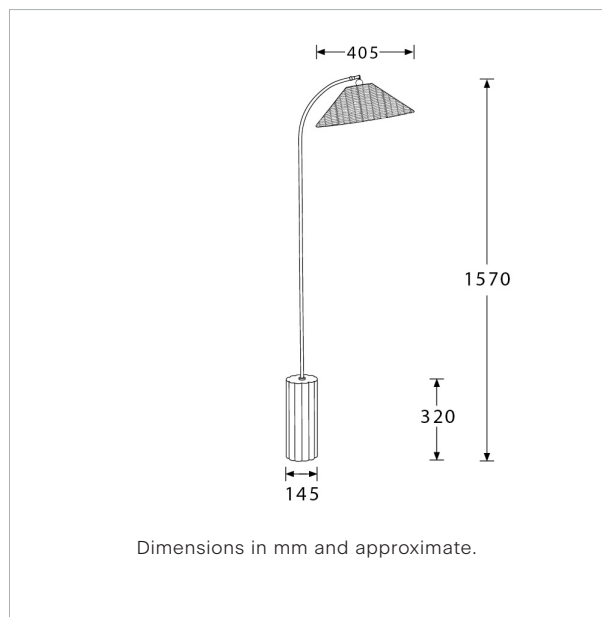

H&
CO

LIGHT BEYOND DESIGN

www.heathfield.co.uk | +44 (0) 1732 350450 | sales@heathfield.co.uk
Unit 1, Priory Road, Tonbridge, Kent, TN9 2AF, United Kingdom. This specification is subject to our standard Terms & Conditions, a copy of which can be found at heathfield.co.uk. © 2023 Heathfield & Co. All rights reserved.