

Heathfield&Co

Product Specification Sheet

CEILING LIGHT | NULA VERTICAL SATIN BRASS



PRODUCT INFORMATION

Base Code: PD-NULA-SBRS-ALAB-V01

Material: Alabaster

Finish shown: White

Metalwork: Satin Brass

Flex: UK & EU 1.5 metres of Oatmeal braided flex /
US Oatmeal braided flex

TECHNICAL INFORMATION

Weight: 1.5kg / 3.3lbs

Switching & Plug: Hardwired

Lamping: Integrated LED 2700 Kelvin

5W Mains Dimmable Driver contained within the
ceiling rose.

IP RATED

TOTAL HEIGHT: 1805 mm / 71¹/₂"

TOTAL WIDTH: 60 mm / 2¹/₂"

UKCA / CE / WIRED USING US COMPONENTS

WARRANTY

10 years*

FINISHING NOTE

Alabaster is a natural material with distinctly unique formations, markings and colouration. It is part of its charm that no two lamps are exactly the same.

CLEANING INSTRUCTIONS

The finishes on this luminaire only require regular cleaning with a soft dry duster. Abrasive or chemical cleaners may harm the finish and should not be used.

FIXING NOTE

It is the buyer's responsibility to ensure that suitable fixings are used. The Nula pendant must be installed with the driver and cannot be wired directly into the mains.

*Please refer to our Terms & Conditions for further information.

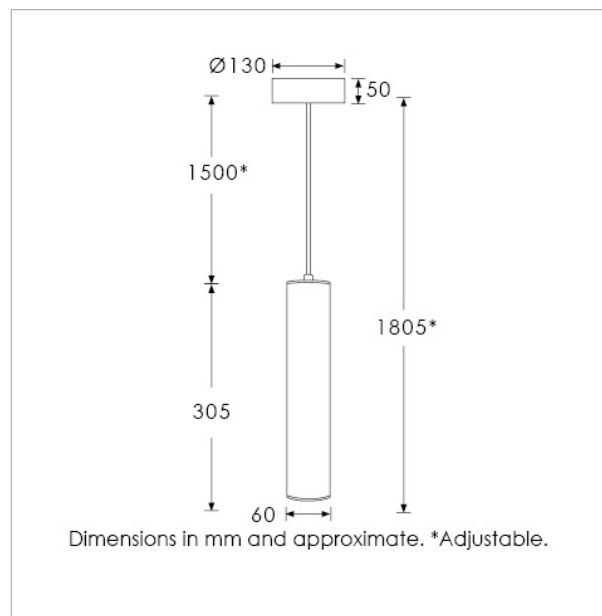

H&
CO

LIGHT BEYOND DESIGN

Heathfield&Co

Product Specification Sheet

CEILING LIGHT | NULA VERTICAL BRONZE



PRODUCT INFORMATION

Base Code: PD-NULA-DBRZ-ALAB-V01

Material: Alabaster

Finish shown: White

Metalwork: Bronze

Flex: UK & EU 1.5 metres of Oatmeal braided flex /
US Oatmeal braided flex

TECHNICAL INFORMATION

Weight: 1.5kg / 3.3lbs

Switching & Plug: Hardwired

Lamping: Integrated LED 2700 Kelvin

5W Mains Dimmable Driver contained within the
ceiling rose.

IP RATED

TOTAL HEIGHT: 1805 mm / 71¹/₂"

TOTAL WIDTH: 60 mm / 2¹/₂"

UKCA / CE / WIRED USING US COMPONENTS

WARRANTY

10 years*

FINISHING NOTE

Alabaster is a natural material with distinctly unique formations, markings and colouration. It is part of its charm that no two lamps are exactly the same.

CLEANING INSTRUCTIONS

The finishes on this luminaire only require regular cleaning with a soft dry duster. Abrasive or chemical cleaners may harm the finish and should not be used.

FIXING NOTE

It is the buyer's responsibility to ensure that suitable fixings are used.

*Please refer to our Terms & Conditions for further information.

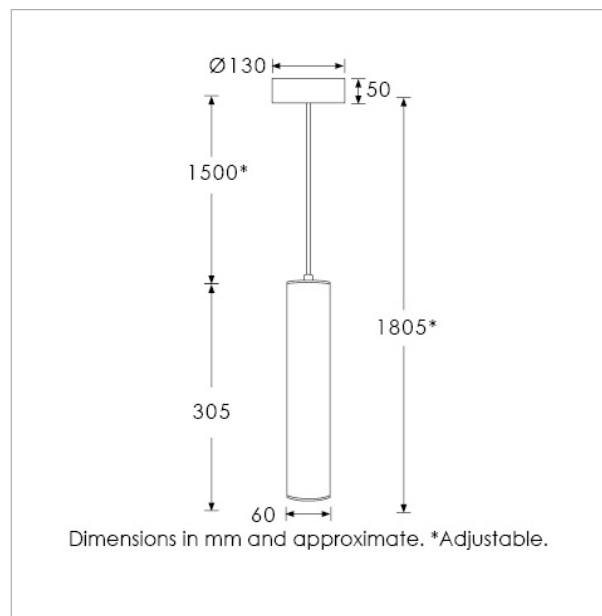

H&CO

LIGHT BEYOND DESIGN