

# Heathfield&Co

## Product Specification Sheet

CEILING LIGHT | KOBI DOUBLE DRUM PENDANT



### PRODUCT INFORMATION

Base Code: PD-KOBI-BRNZ  
Material: Metal  
Finish shown: Blackened Bronze  
Lampshade: 19" Kobi Double Drum / SH-19-KOBI  
Flex: UK & EU 1.5 metres of Black braided flex /  
US Black braided flex

### TECHNICAL INFORMATION

Weight: 1.1kg / 2.4lbs  
Switching & Plug: Hardwired  
Lamping: 1x E27 lampholder / 1x E26 US lampholder  
40W max. LED lamps recommended.  
Lamps not included

TOTAL HEIGHT: 1970 mm / 77<sup>1</sup>/<sub>2</sub>"

TOTAL WIDTH: 455 mm / 18"

UKCA / CE / UL COMPLIANT

### WARRANTY

12 months

### FINISHING NOTE

All metalwork is handcrafted and may vary from piece to piece with slight variation in finish and detailing.

### CLEANING INSTRUCTIONS

The finishes on this luminaire only require regular cleaning with a soft dry duster. Abrasive or chemical cleaners may harm the finish and should not be used. Shade to be dusted with a clean dry cloth.

### FIXING NOTE

It is the buyer's responsibility to ensure that suitable fixings are used.

\*Please refer to our Terms & Conditions for further information.

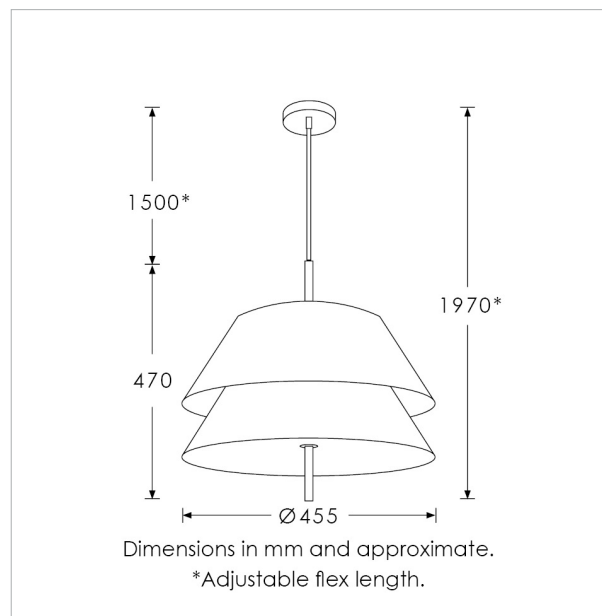

H&  
CO

LIGHT BEYOND DESIGN