

Heathfield&Co

Product Specification Sheet

CEILING LIGHT | INDI



PRODUCT INFORMATION

Base Code: PD-INDI-SBRS-ANTI-P00-STD

Material: Metal & Glass

Finish shown: Clear

Flex: UK & EU 1.5 metres of Oatmeal braided flex /
US Oatmeal braided cable

TECHNICAL INFORMATION

Weight: 1kg / 2.2lbs

Switching & Plug: Hardwired

Lamping: 1x G9 lampholder / 1x G9 US lampholder
5W max. LED lamps recommended.

Lamps not included

TOTAL HEIGHT: 1850 mm / 72^{3/4}"

TOTAL WIDTH: 120 mm / 4^{3/4}"

UKCA / CE / WIRED USING US COMPONENTS

WARRANTY

10 years*

FINISHING NOTE

Our carefully selected glass and metalwork components are all hand finished by skilled artisans and as such no two products are exactly the same - something that adds to the unique charm of this product.

CLEANING INSTRUCTIONS

The finishes on this luminaire only require regular cleaning with a soft dry duster. Abrasive or chemical cleaners may harm the finish and should not be used.

FIXING NOTE

It is the buyer's responsibility to ensure that suitable fixings are used.

*Please refer to our Terms & Conditions for further information.

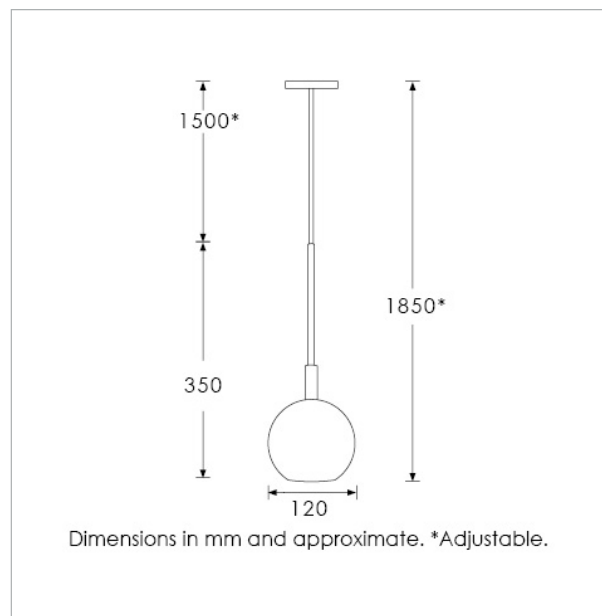

H&
CO

LIGHT BEYOND DESIGN

Heathfield&Co

Product Specification Sheet

CEILING LIGHT | INDI 3 LIGHT CLUSTER SATIN BRASS



PRODUCT INFORMATION

Base Code: PD-INDI-SBRS-ANTI-V03

Material: Brass & Glass

Finish shown: Clear

Metalwork: Satin Brass

TECHNICAL INFORMATION

Weight: 3kg / 6.6lbs

Switching & Plug: Hardwired

Lamping: 3x G9 Lampholder / 3x G9 US lampholder

25W max. LED Lamps Recommended.

Lamps not included

TOTAL HEIGHT: 2385mm / 94"

TOTAL WIDTH: 250mm / 10"

CEILING ROSE HEIGHT: 35mm / 1 1/2"

CEILING ROSE WIDTH: 250mm / 10"

UKCA / CE / WIRED USING US COMPONENTS

WARRANTY

10 years*

FINISHING NOTE

Our carefully selected glass and metalwork components are all hand finished by skilled artisans and as such no two products are exactly the same - something that adds to the unique charm of this product.

CLEANING INSTRUCTIONS

The finishes on this luminaire only require regular cleaning with a soft dry duster. Abrasive or chemical cleaners may harm the finish and should not be used.

FIXING NOTE

It is the buyer's responsibility to ensure that suitable fixings are used.

*Please refer to our Terms & Conditions for further information.

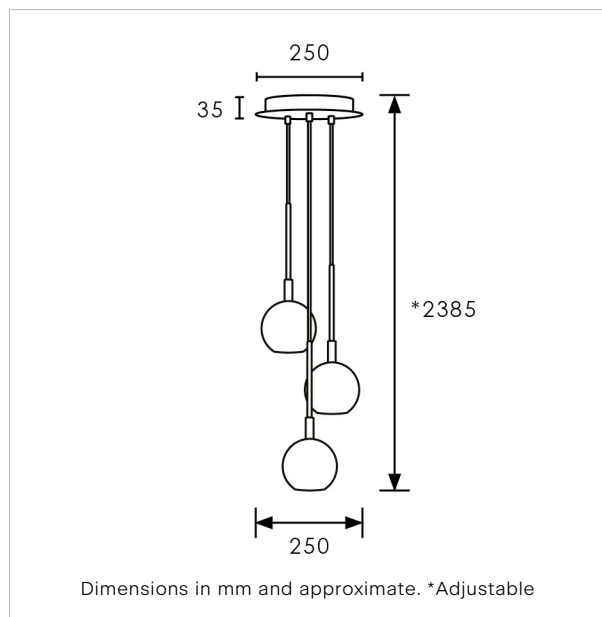

**H&
CO**

LIGHT BEYOND DESIGN

www.heathfield.co.uk | +44 (0) 1732 350450 | sales@heathfield.co.uk
Unit 1, Priory Road, Tonbridge, Kent, TN9 2AF, United Kingdom. This specification is subject to our standard Terms & Conditions, a copy of which can be found at heathfield.co.uk. © 2025 Heathfield & Co. All rights reserved.

Heathfield&Co

Product Specification Sheet

CEILING LIGHT | INDI 5 LIGHT CLUSTER SATIN BRASS



PRODUCT INFORMATION

Base Code: PD-INDI-SBRS-ANTI-V05

Material: Brass & Glass

Finish shown: Clear

Metalwork: Satin Brass

TECHNICAL INFORMATION

Weight: 5kg / 11lbs

Switching & Plug: Hardwired

Lamping: 5x G9 Lampholder / 5x G9 US lampholder

25W max. LED Lamps Recommended.

Lamps not included

TOTAL HEIGHT: 2390mm / 94¹/₄"

TOTAL WIDTH: 370mm / 14¹/₂"

CEILING ROSE HEIGHT: 40mm / 1³/₄"

CEILING ROSE WIDTH: 370mm / 14¹/₂"

UKCA / CE / WIRED USING US COMPONENTS

WARRANTY

10 years*

FINISHING NOTE

Our carefully selected glass and metalwork components are all hand finished by skilled artisans and as such no two products are exactly the same - something that adds to the unique charm of this product.

CLEANING INSTRUCTIONS

The finishes on this luminaire only require regular cleaning with a soft dry duster. Abrasive or chemical cleaners may harm the finish and should not be used.

FIXING NOTE

It is the buyer's responsibility to ensure that suitable fixings are used.

*Please refer to our Terms & Conditions for further information.

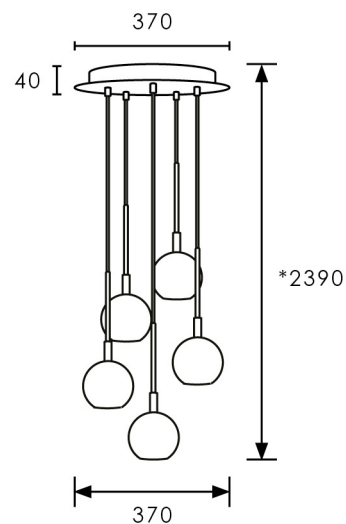

Dimensions in mm and approximate. *Adjustable

H&
CO

LIGHT BEYOND DESIGN

www.heathfield.co.uk | +44 (0) 1732 350450 | sales@heathfield.co.uk
Unit 1, Priory Road, Tonbridge, Kent, TN9 2AF, United Kingdom. This specification is subject to our standard Terms & Conditions, a copy of which can be found at heathfield.co.uk. © 2025 Heathfield & Co. All rights reserved.