

Heathfield&Co

Product Specification Sheet

CEILING LIGHT | DAHLIA



PRODUCT INFORMATION

Base Code: PD-DAHL-BRNZ-BLAN

Material: Glass & Metal

Metalwork: Blackened Bronze

Finish shown: Blanc

TECHNICAL INFORMATION

Weight: 6.8kg / 15lbs

Switching & Plug: Hardwired

Lamping: 3x G9 lampholder / 3x G9 US lampholder
25W max. LED lamps recommended.

Lamps not included

TOTAL HEIGHT: 240 mm / 9¹/₂"

TOTAL WIDTH: 720 mm / 28¹/₄"

UKCA / CE / WIRED USING US COMPONENTS

IP44 RATED

WARRANTY

10 years*

FINISHING NOTE

Our carefully selected glass and metalwork components are all hand finished by skilled artisans and as such no two products are exactly the same - something that adds to the unique charm of this product.

CLEANING INSTRUCTIONS

The finishes on this luminaire only require regular cleaning with a soft dry duster. Abrasive or chemical cleaners may harm the finish and should not be used.

FIXING NOTE

It is the buyer's responsibility to ensure that suitable fixings are used.

*Please refer to our Terms & Conditions for further information.

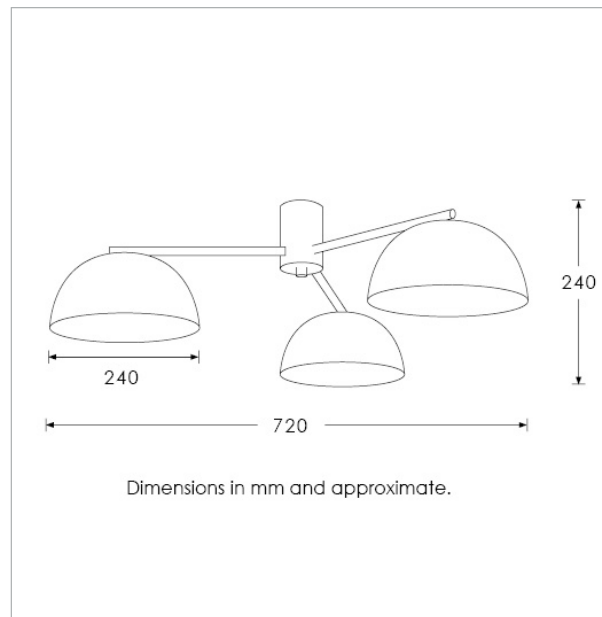

H&
CO

LIGHT BEYOND DESIGN