

# Heathfield&Co

## Product Specification Sheet

CEILING LIGHT | COSMO BLACKENED BRONZE



### PRODUCT INFORMATION

Base Code: PD-COSM-BRNZ-WHTE  
Material: Brass & Glass  
Metalwork: Blackened Bronze  
Finish shown: White grain  
Flex: UK & EU 1.5 metres of Black braided cable / US Black braided cable

### TECHNICAL INFORMATION

Weight: 1.7kg / 3.7lbs  
Switching & Plug: Hardwired  
Lamping: 1x G9 lampholder  
25W max. LED lamps recommended - max. 50mm length G9 bulb required.  
Lamps not included.

TOTAL HEIGHT: 1670 mm / 65<sup>3/4</sup>" TOTAL  
WIDTH: 380 mm / 15"

UKCA / CE / WIRED USING US  
COMPONENTS

### WARRANTY

10 years\*

### FINISHING NOTE

Our carefully selected glass and metalwork components are all hand finished by skilled artisans and as such no two products are exactly the same - something that adds to the unique charm of this product.

### CLEANING INSTRUCTIONS

The finishes on this luminaire only require regular cleaning with a soft dry duster. Abrasive or chemical cleaners may harm the finish and should not be used.

### FIXING NOTE

It is the buyer's responsibility to ensure that suitable fixings are used.

\*Please refer to our Terms & Conditions for further information.

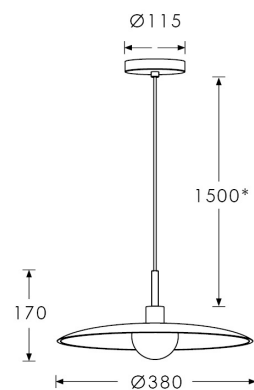

Dimensions in mm and approximate. \*Adjustable flex length.

H&  
CO

LIGHT BEYOND DESIGN

# Heathfield&Co

## Product Specification Sheet

CEILING LIGHT | COSMO SATIN BRASS



### PRODUCT INFORMATION

Base Code: PD-COSM-SBRS-WHTE

Material: Brass & Glass

Metalwork: Satin Brass

Finish shown: White grain

Flex: UK & EU 1.5 metres of Hessian braided cable / US Hessian braided cable

### TECHNICAL INFORMATION

Weight: 1.7kg / 3.7lbs

Switching & Plug: Hardwired

Lamping: 1x G9 lampholder

25W max. LED lamps recommended - max.

50mm length G9 bulb required. Lamps not included

TOTAL HEIGHT: 1670 mm / 65<sup>3/4</sup>"

TOTAL WIDTH: 380 mm / 15"

UKCA / CE / WIRED USING US COMPONENTS

### WARRANTY

10 years\*

### FINISHING NOTE

Our carefully selected glass and metalwork components are all hand finished by skilled artisans and as such no two products are exactly the same - something that adds to the unique charm of this product.

### CLEANING INSTRUCTIONS

The finishes on this luminaire only require regular cleaning with a soft dry duster. Abrasive or chemical cleaners may harm the finish and should not be used.

### FIXING NOTE

It is the buyer's responsibility to ensure that suitable fixings are used.

\*Please refer to our Terms & Conditions for further information.

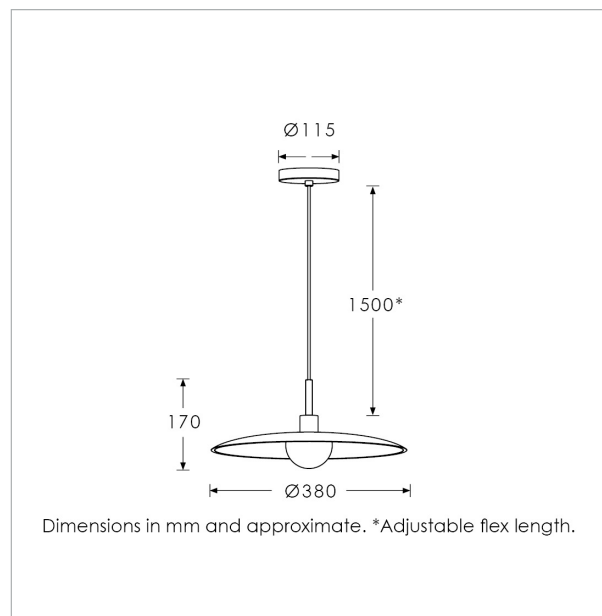

H&  
CO

LIGHT BEYOND DESIGN